

B-10



Motor

Top quality manufacturing by CNC machines of high technology without human touch, Circuit breaker equipped with thermal thermic and actuated in case of overheating and resistance, Monophase fan motor of 230-240 V / 50 Hz,

Fields of Use:

To discharge the moist and humid air out of the bathrooms,
To discharge the air out of the environment, where the air is dirty,
To discharge the unwanted odors and smokes out of the houses.

B-10, B-12

Fully built-in design for wall and ceiling applications.
Moreover, double glasses of 28 mm can be mounted.
Quick Fix System does not require any screws or fixing plugs.

Fan Body and Propeller

Fan's body and fan blades are produced of ABS plastic,
In accordance with the standards of EN 60335-2-80,
Low Noise Level

Important Information:

Product data and technical values may vary according to the operation location and conditions. All of the data given herein have been measured according to standards of TSE and EC norms Noise level measurements have been taken at a distance of 1,5 m from the related product. The recommended lifespan is 10 years. All of our products are certified with the guaranty certificate approved by the Ministry of Industry. Guaranty period is 2 years.

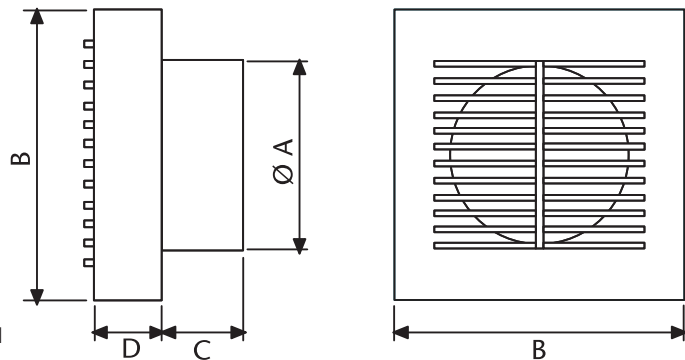

	ØA	B	C	D
B-10	98	150	42	35
B-12	118	180	45	44
B-15	148	209	60	45

In combination with light, fan switches on

Timer

Hygro

Pull cord

MODEL	Volt (V)	r.p.m.	W	MAX.		dB (A)	Weight (kg)	Package Pcs.
				m ³ /h	mm H ₂ O			
B-10	230 V ~ 50 Hz.	2500	15	98	3	41	0,6	6
B-12	230 V ~ 50 Hz.	2450	20	190	5	43	0,85	6
B-15	230 V ~ 50 Hz.	2100	25	320	8	43	0,95	6

Domestic Fans